

Code: 006S00002
F1/241 - 400V 50Hz - 2.0HP 2P

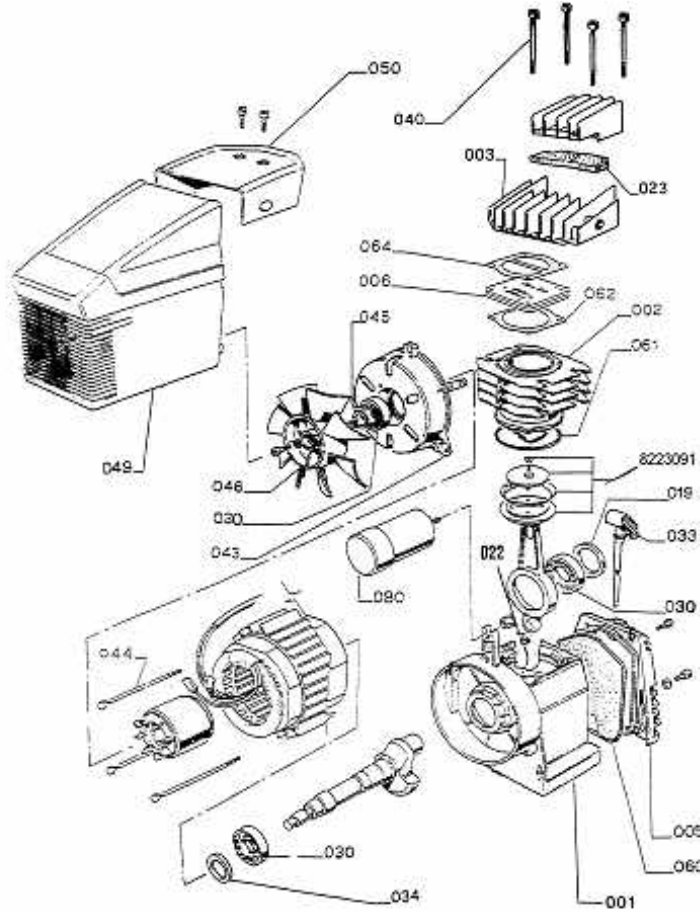

Dimensions:

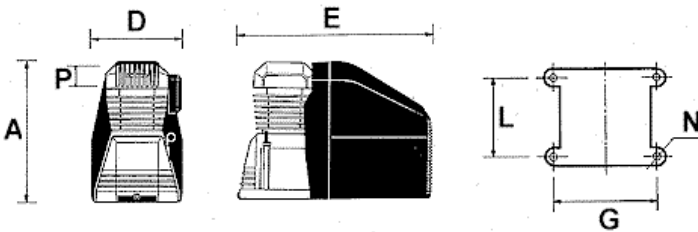

In mm

A	B	C	D	E	F	G	L	M	N	P
270	/	/	165	375	/	139	64	/	9	3/8" F

Box Weight: Kg Box Dimensions: W x D x L: x x

Tightening Torques, Cylinder Head:

Bolt Size:	<input type="text" value="M6"/>	
Min Torque:	<input type="text" value="9.3"/>	Nm
Max Torque:	<input type="text" value="11.36"/>	Nm

Technical Data:

Cylinders:	<input type="text" value="1"/>			
Stages:	<input type="text" value="1"/>			
Air Flow:	<input type="text" value="240"/>	L/min	<input type="text" value="8.5"/>	cfm
Power:	<input type="text" value="1.5"/>	Kw	<input type="text" value="2"/>	HP
Speed:	<input type="text" value="2850"/>	rpm		
Max Pressure:	<input type="text" value="8"/>	Bar	<input type="text" value="116"/>	psi

Code: 00 6S00002
F1/241 - 400V 50Hz - 2.0HP 2P



<i>Svc</i>	<i>Ref</i>	<i>Code</i>	<i>Description</i>	<i>Qty</i>	<i>Modified</i>
<input type="checkbox"/>	001	00 7161100	Crankase	1	
<input type="checkbox"/>	002	00 6P30001	Cylinder	1	
<input type="checkbox"/>	003	00 7361400	Pump head	1	
<input type="checkbox"/>	005	00 7161300	Crankase gasket	1	
<input checked="" type="checkbox"/>	006	00 0540051	Valve plate assy.	1	
<input type="checkbox"/>	022	00 9014009	Oil dipper	1	
<input checked="" type="checkbox"/>	023	00 7181100	Filter	1	
<input type="checkbox"/>	030	00 9170097	Bearing	1	
<input type="checkbox"/>	030	00 9170030	Bearing	1	
<input type="checkbox"/>	030	00 9170091	Bearing	1	
<input type="checkbox"/>	030	00 9170060	Bearing	1	12.11.2000
<input type="checkbox"/>	033	00 9024015	Oil fill plug	1	
<input type="checkbox"/>	034	00 9163010	Oil seal	1	
<input type="checkbox"/>	040	00 9101124	Cylinder head bolts	4	
<input type="checkbox"/>	040	00 9011043	Cylinder head bolts	4	31.03.2003
<input type="checkbox"/>	043	00 6562203	Motor cover	1	
<input type="checkbox"/>	044	00 9011040	Motor bolts	3	
<input type="checkbox"/>	045	00 9140170	Circlip	1	
<input type="checkbox"/>	045	00 9140160	Circlip	1	
<input type="checkbox"/>	046	00 9038017	Fan	1	
<input type="checkbox"/>	049	00 830190A	Cover	1	
<input type="checkbox"/>	050	00 830130A	Cover plate	1	
<input type="checkbox"/>	060	00 7150100	Crankase gasket	1	
<input type="checkbox"/>	061	00 6P50200	Crankase cylinder gasket	1	
<input checked="" type="checkbox"/>	062	00 7350300	Cylinder - plate gasket	1	
<input checked="" type="checkbox"/>	064	00 6750400	Plate - head gasket	1	

Svc = Service Item