

**Code: 00 75A0000**  
**F1/260 - 230V 50Hz - 2.5HP**

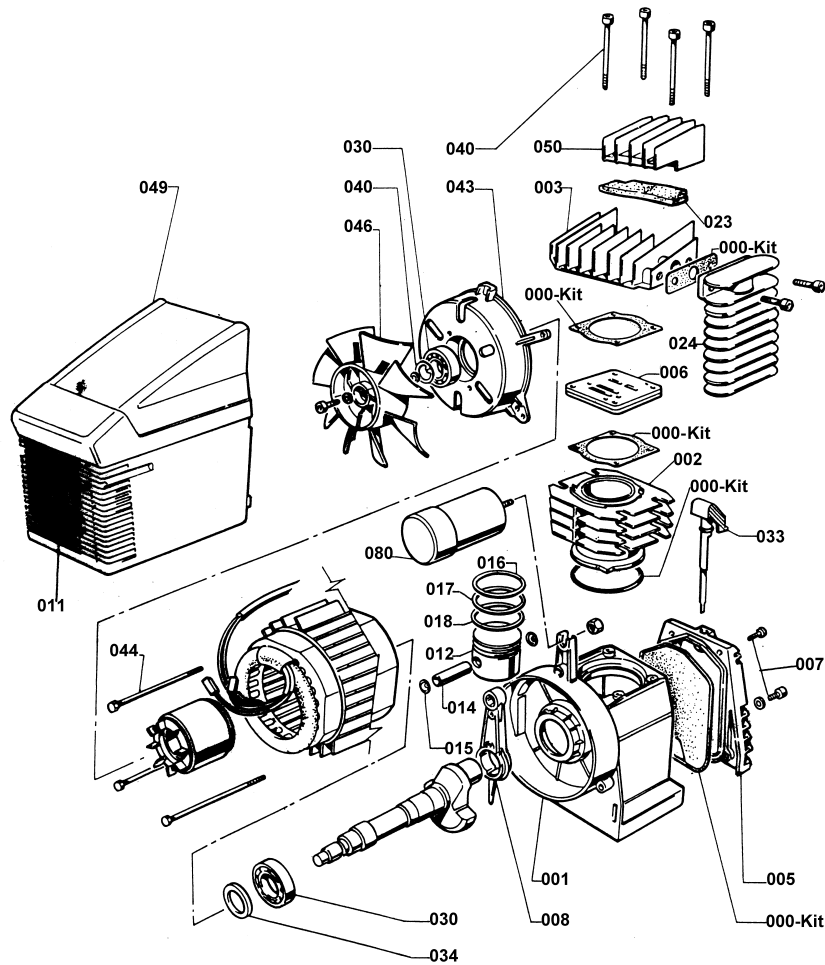

**Dimensions:**

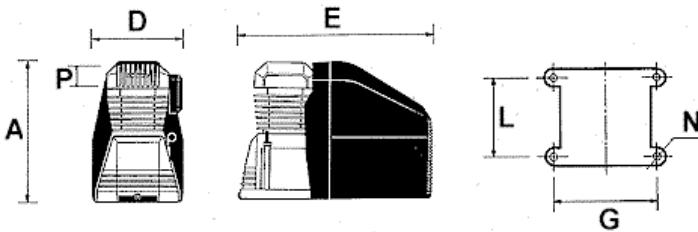

In mm

A	B	C	D	E	F	G	L	M	N	P
270	/	/	165	375	/	139	64	/	9	1/2" M

Box Weight: 13 Kg Box Dimensions: W x D x L: 186 x 396 x 302

**Tightening Torques, Cylinder Head:**

Bolt Size:	M6	
Min Torque:	9.3	Nm
Max Torque:	11.36	Nm

**Technical Data:**

Cylinders:	1		
Stages:	1		
Air Flow:	260	L/min	9.2 cfm
Power:	1.8	Kw	2.5 HP
Speed:	2850	rpm	
Max Pressure:	8	Bar	116 psi

**Code: 00 75A0000**  
**F1/260 - 230V 50Hz - 2.5HP**



<i>Svc</i>	<i>Ref</i>	<i>Code</i>	<i>Description</i>	<i>Qty</i>	<i>Modified</i>
<input checked="" type="checkbox"/>	000	00 7850050	Gasket Kit	1	
<input type="checkbox"/>	001	00 7161100	Crankase	1	
<input type="checkbox"/>	002	00 7230000	Cylinder	1	
<input type="checkbox"/>	003	00 7261400	Pump head	1	
<input type="checkbox"/>	005	00 7161300	Crankase gasket	1	
<input checked="" type="checkbox"/>	006	00 0540051	Valve plate assy.	1	
<input type="checkbox"/>	008	00 7110100	Connecting rod	1	
<input type="checkbox"/>	012	00 7921100	Piston D. Pin D.	1	
<input type="checkbox"/>	014	00 6721200	Pin	1	
<input type="checkbox"/>	015	00 9140020	Circlip	2	
<input type="checkbox"/>	016	00 9020017	Piston ring AC	1	
<input type="checkbox"/>	017	00 9020034	Piston ring ROS	1	
<input type="checkbox"/>	018	00 9020064	Piston ring ROF	1	
<input checked="" type="checkbox"/>	023	00 7181100	Filter	1	
<input type="checkbox"/>	030	00 9170030	Bearing	1	
<input type="checkbox"/>	030	00 9170091	Bearing	1	
<input type="checkbox"/>	033	00 9024022	Oil fill plug	1	
<input type="checkbox"/>	034	00 9163010	Oil seal	1	
<input type="checkbox"/>	040	00 9101124	Cylinder head bolts	4	
<input type="checkbox"/>	043	00 6562203	Motor cover	1	
<input type="checkbox"/>	044	00 9011041	Motor bolts	3	
<input type="checkbox"/>	045	00 9140160	Circlip	1	
<input type="checkbox"/>	046	00 9038017	Fan	1	
<input type="checkbox"/>	049	00 830180A	Cover	1	
<input type="checkbox"/>	050	00 830130A	Cover plate	1	
<input type="checkbox"/>	080	00 9067015	Capacitor	1	
<input type="checkbox"/>	112	00 9053003	Connection	1	

*Svc = Service Item*